



Telstra Operations, Network Engineering,
Access Infrastructure

Technical Reference
Document No: RCIT.0004

Splitter Specification for ADSL/POTS
Spectrum Sharing Service, Retail ADSL & Wholesale
ADSL
Issue 3.0

Implementation:

Uncontrolled Document - No Unauthorised Copying

Telstra Corporation Limited
ABN 33 - 051 775 556

TABLE OF CONTENTS

1. PURPOSE	4
2. SCOPE	4
3. PRODUCT DESCRIPTION	4
4. PERFORMANCE OBJECTIVES	5
4.1. General	5
4.2. Exchange Splitter	6
4.2.1. Changes and Clarifications to the ETSI Specification for the Exchange Splitter 6	
4.2.1.1. Testing Conditions (Section 5 of ETSI TS 101.952-1-1 V1.2.1)	6
4.2.1.1.1 Feed currents	6
4.2.1.1.2 Impedances.....	6
4.2.1.2. Splitter Requirements (Section 6 of ETSI TS 101.952-1-1 V1.2.1).....	7
4.2.1.2.1 Option A Splitters	7
4.2.1.2.2 DC Resistance to Earth.....	7
4.2.1.2.3 DC Insulation Resistance between A-wire and B-wire	7
4.2.1.2.4 POTS Pass Band Return Loss Requirements (off-hook)	7
4.2.1.2.5 Immunity to High Level POTS Signals	7
4.2.1.2.6 Unbalance about Earth.....	8
4.2.1.2.7 Metering Signals	8
4.2.1.2.8 Signature Networks (Section 7.1 of ETSI TR 101.728 V1.2.1 (2002-05))	8
4.2.1.2.9 Weak High Pass Filter in the Splitter Unit.....	8
4.2.1.2.10 Requirements for Common Mode rejection	8
4.2.2. Additions Not Covered in ETSI Specification Applicable to Exchange Splitters	8
4.3. Customer End Splitter	9
4.3.1. Clarification to the AS/ACIF Specification for the Customer End Centralised and Distributed Splitters (EXPLANATORY – not for compliance)	9
4.3.1.1. General Functional Description of Splitters (Section 5.3 of AS/ACIF S041.3: 2009).....	9
4.3.1.1.1 DC Current Range	9
4.3.1.1.2 Reference Impedance	9

4.3.1.1.3 Return Loss.....	10
4.3.1.1.4 POTS Compatibility Tests	10
4.3.2. Other Requirements Applicable to Customer End Splitters (EXPLANATORY – not for compliance)	11
5. DEFINITIONS.....	11
6. REFERENCES	12
7. DOCUMENT CONTROL SHEET	14

1. PURPOSE

The purpose of this Technical Reference is to provide the technical requirements for Splitters located at both exchange and customer premises ends of a loop for all splitter applications on Telstra lines which also carry Telstra POTS and ADSL, ADSL2, or ADSL2+. This includes Shared Spectrum services, Telstra Retail ADSL and Telstra Wholesale ADSL.

2. SCOPE

Splitters for both exchange and customer premises ends of a loop between ADSL and POTS must be provided as part of the overlaid ADSL, ADSL2 or ADSL2+ service. The following specifications shall be met by those splitters. For exchange splitters, this Technical Reference uses the requirements stipulated within the ETSI Technical Report and Technical Specification for low pass filters with certain alterations, limitations and additions to suit Australian and Telstra conditions. For Customer Premises (Remote) splitters, this Technical Reference uses the requirements stipulated within the AS/ACIF S041.1 and S041.3:2009 Australian Standard for DSL customer equipment with certain additional recommendations and implementation rules to suit Telstra conditions.

These requirements are considered necessary to allow satisfactory operation of voice-band CPE currently in use.

This Technical Reference does not contain Customer Premises splitter usage information; this is contained in Technical Reference RCIT.0006, Customer End Splitter Information for ADSL/POTS Spectrum Sharing.

Note that mandatory requirements in this specification are indicated by the use of “shall”, while recommended non-mandatory requirements use “should”.

3. PRODUCT DESCRIPTION

The Shared Spectrum services, Telstra Retail ADSL and Telstra Wholesale ADSL products use vacant frequency spectrum, at frequencies above an existing voice-band PSTN service provided by Telstra. These products will be provided on an unconditioned communications pair between the boundary of a telecommunications network at an end-user's premises and a point on a telecommunications network that is a potential point of interconnection located at, or associated with, either a Telstra customer access module (CAM), or an Acquirer's CAM (for Shared Spectrum services), and located on the end-user side of the customer access module.

These products will be provided over a single existing twisted metallic pair. Acquirers (for Shared Spectrum services) and Telstra provide their own DSLAMs, compliant ADSL, ADSL2 or ADSL2+ modems and compliant filters that are suitable for connection to the Telstra network. Spectrum Sharing Acquirers will also be required to install a Network Termination Device (NTD) at the end-customer premises when applicable. Spectrum Sharing is available nationally subject to the Acquirer having rolled out their equipment.

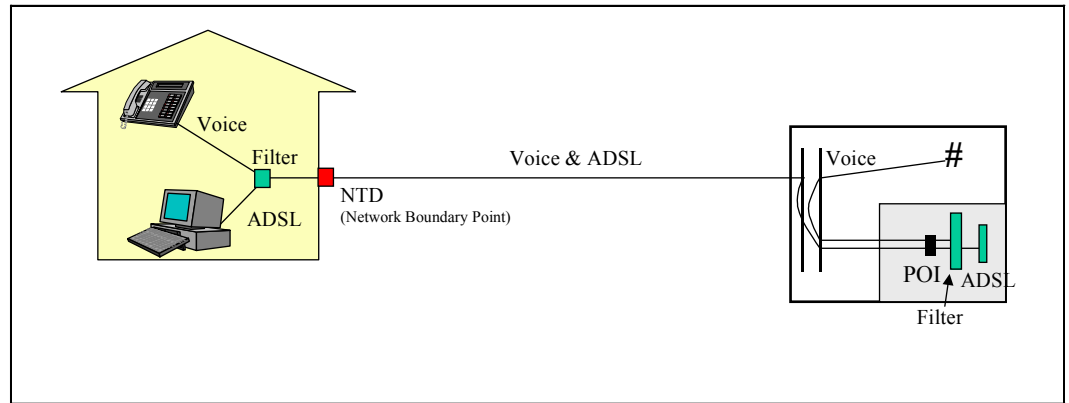

Figure 1 – Telstra Wholesale Spectrum Sharing Service (End-to-End View)

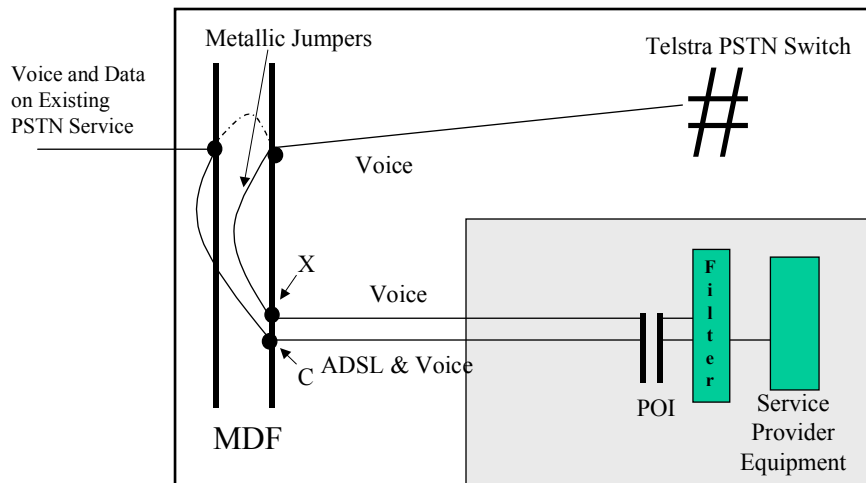

Figure 2 – Telstra Wholesale Spectrum Sharing Service (Voice provided by Telstra, ADSL provided by Acquirer)

4. PERFORMANCE OBJECTIVES

4.1. General

For the exchange splitter, ETSI has published the final Technical Specification (TS) ETSI TS 101 952-1-1 V1.2.1 (2004-12): "Specification of the low pass part of ADSL/POTS splitters". This document is Part 1, Sub-part 1 of a series of documents covering access network xDSL transmission filters. The other document of interest, for the customer splitter (including centralised and distributed) is AS/ACIF S041.3:2009 "Requirements for DSL Customer Equipment for connection to the Public Switched Telephone Network" which was published in May 2009.

4.2. Exchange Splitter

The exchange end splitter is cabled from the telephony port back to the MDF to enable further jumpering to the telephone switch.

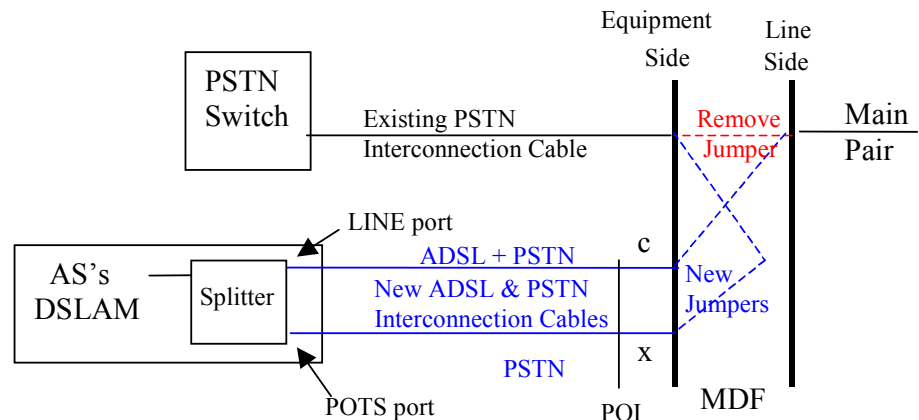

Figure 3 – Splitter in Acquirer's Equipment

The splitter provides a low pass filtering functionality in the telephony path, to effectively decouple the ADSL and telephony services.

The low pass filtering at the exchange end shall meet the requirements of ETSI TS 101 952-1-1 V1.2.1 (2004-12) for ADSL over POTS and ADSL2+ over POTS technologies with the exclusions, explanations and changes listed below. These changes have been made for the Australian telecommunications environment.

Note, all tests in ETSI TS 101 952-1-1 V1.2.1 (2004-12) shall be performed at both line polarities and at both maximum and minimum line current, i.e. all tests in ETSI TS 101 952-1-1 V1.2.1 (2004-12) shall be repeated at four line conditions.

4.2.1. Changes and Clarifications to the ETSI Specification for the Exchange Splitter

4.2.1.1. Testing Conditions (Section 5 of ETSI TS 101.952-1-1 V1.2.1)

Note that this standard requires compliance to the parameters specified in Table A-2 of ETSI TS 101 952-1-1 V1.2.1 (2004-12) for only one of the listed technologies. For a splitter that will be used only with ADSL1 technology, the applicable column is "ADSL or ADSL2 over POTS". For a splitter that will be used with ADSL2+ technology (including mixed ADSL1 and ADSL2+ use), the applicable column is "ADSL2+ over POTS deployed from the LE".

4.2.1.1.1 Feed currents

For Clause 5.1.2, feed currents up to 125mA DC may be encountered in Australia. During the transition from the Ringing to the Off-hook state, large transient currents in excess of 200mA may occur. However the requirements for testing remain as in Clause 5.1.2.

4.2.1.1.2 Impedances

The ETSI specifications of return loss, etc. are based on the European harmonized impedance Z_R (Clause 5.2.2)

Note that the European harmonized impedance Z_R is a close match to the Australian TN12 complex impedance. Hence either impedance can be used as the reference impedance for testing. For example if the splitter passes with Z_R , then there is no need to

test with TN12 (and vice versa). If a result fails marginally with Z_R then TN12 can be used as it may pass with this slightly different impedance TN12 (and vice versa).

4.2.1.2. Splitter Requirements (Section 6 of ETSI TS 101.952-1-1 V1.2.1)

4.2.1.2.1 Option A Splitters

Option A splitters are required.

4.2.1.2.2 DC Resistance to Earth

In Clause 6.2.1 the DC resistance between terminals and earth shall not be less than 10 M Ω when tested with 250 V DC.

4.2.1.2.3 DC Insulation Resistance between A-wire and B-wire

In Clause 6.2.2 the DC resistance between terminals and earth shall not be less than 10 M Ω when tested with 250 V DC.

4.2.1.2.4 POTS Pass Band Return Loss Requirements (off-hook)

In Clause 6.6, the return loss limits in tests 3 and 4 may be measured with the TN12 impedance (described in 4.2.1.1.2) in place of the Z_R impedance.

Z_{SL} is based on a short line terminated in 600 Ω . Compliance with tests 1 and 2 based on the Z_{SL} reference impedance is sufficient but not necessary for compliance with RCIT.0004. If the requirements of the Z_{SL} tests in 6.6.1 of ETSI TS 101.952-1-1 are not met, alternative tests for compliance in tests 1 and 2 may be performed with the following reference impedances.

- Return loss at the POTS port may use a reference impedance of Z_{SL} with a TN12 load impedance at the line port.
- Return loss at the Line port may use a reference impedance of TN12 with a Z_{SL} load impedance at the POTS port.

The open circuit test for the Z_{ADSL} impedance does not need to be performed if either:

1. The exchange end ADSL modem has an integrated low pass splitter, or
2. The procedures for removal of exchange based ADSL equipment are such that the ADSL modem and splitter are removed together.

4.2.1.2.5 Immunity to High Level POTS Signals

In Clause 6.13, ETSI have stated that the need for this test and the test method are for further study. However, this requirement is still highly desirable, to the limits set out in Annex B.

An important requirement of a POTS splitter/filter is to prevent any unwanted signals at DSL frequencies being generated due to the presence of high voltage signals/transients present on the line. The effect of such frequencies on the modem can be twofold. The high voltage swing on the line generates a corresponding high voltage signal at the receiver of the modem which can, at the very least, make the receiver go non-linear. At worst it can cause clipping. The other effect is that the frequency content of the high voltage swing will overlap the frequencies used for the upstream transmission, causing a reduction of signal to noise ratio for the carriers and hence increased error rate.

High voltage swings are created under a number of circumstances. The obvious condition is when a telephone goes off-hook or goes back on-hook. Loop disconnect dialling also causes high voltage swings. Indeed older telephones literally short out the line. High voltage swings also occur at the line-card of the local exchange when line reversal is used. Thus measurement of the large signal performance is necessary for both the LE and remote splitter/filters.

Note that the test circuit Figure B.1 for large signal test, is for the testing of a CPE splitter. For a LE filter the 48V feed and switch is connected to the POTS (exchange) side and the line port is terminated with a 600 Ω termination.

4.2.1.2.6 Unbalance about Earth

The Unbalance about Earth requirements in Table 8 must be tightened and compliant equipment shall meet the requirements in the following table.

Frequency range	State of S1	Value of R	Minimum Unbalance value
50 Hz to 600 Hz	closed	300	46 dB
600 Hz to 3400 Hz	closed	300	52 dB
3400 Hz to 4000 Hz	closed	300	46 dB
4 kHz to 32 kHz	open	50	40 dB
32 kHz to f_H kHz	open	50	50 dB
f_H kHz to 5 MHz	open	50	30 dB

4.2.1.2.7 Metering Signals

The splitter does not need to accommodate 12 kHz, 16 kHz or 50 Hz metering signals.

4.2.1.2.8 Signature Networks (Section 7.1 of ETSI TR 101.728 V1.2.1 (2002-05))

Signature Networks in Clause 7.1 are unacceptable if they cause the insulation resistance tests in 5.1.2 or 5.1.3 to fail.

4.2.1.2.9 Weak High Pass Filter in the Splitter Unit

Where the cable between the splitter and the Acquirer's DSLAM is greater than 50m in length, then a weak high pass filter should be implemented in the splitter unit as shown in the configuration of Figure 3 in Section 4.3 of ETSI TR 101.728 V1.2.1 (2002-05). The components used should be as called up in ETSI TS 101 952-1-2 V1.2.1 (2004-12) Section 6.1 Option B: 1st order filter.

4.2.1.2.10 Requirements for Common Mode rejection

Because some POTS transient signals include significant common mode components, it is desirable to have a degree of common mode rejection within the exchange splitter. Specifically, the splitter should meet the requirements of 6.14 and Figure 15 of ETSI TS 101 952-1-1 V1.2.1 (2004-12).

4.2.2. Additions Not Covered in ETSI Specification Applicable to Exchange Splitters

Loss of power to the splitter or Acquirer's DSLAM, or other operations such as card changes in the DSLAM shall not result in a reduction in performance or disconnection of the telephone service, although a short break of up to 10ms is permitted.

In order to avoid unacceptable degradation of Telstra's exchange testing, the total capacitance between A and B legs of the splitter with DSLAM connected shall be less than 150nF.

The ADSL service provider may apply test signals within the ADSL bands at any time provided those test signals are compliant with the ACIF Network Deployment Rules Code C559, either belonging to an existing Deployment Class or demonstrated to be compliant under the provisions for Non-deployment Class systems.

Testing of the line at DC or voice frequency may only be performed when the telephone service is inactive; in this case the method of determination of inactivity and the duration of the test is to be determined in consultation with Telstra.

Additionally, the splitter may optionally incorporate relay bypass to enable testing from the telephony port without the splitter or DSLAM connected.

The following paragraph is for information only, i.e. not tested for this specification.

DSLAM ADSL equipment must comply with the relevant ADSL transmit PSD masks and deployment rules of ITU-T G.992.1, ITU-T G.992.5 and ACIF C559-3.

4.3. Customer End Splitter

The customer end splitter may be implemented as a centralized or an in-line (distributed) splitter. New customer premises' cabling is to be provided from the centralized splitter to the ADSL CPE; it is unacceptable practice to use the alternate (red and black) pair in the customer premises wiring to connect the modem to the central splitter. The splitter provides a low pass filtering functionality in the telephony path. The high pass component of the splitter is assumed to be in the ADSL CPE.

The low pass filtering at the customer end centralised splitter shall comply with the requirements of Australian Standard AS/ACIF S041.1:2009 and S041.3:2009. The combined effect of up to 3 in-line filters shall also comply with the requirements of Australian Standard AS/ACIF S041:2009. Telstra does not impose any further requirements beyond those of AS/ACIF S041:2009, except to reiterate the disclaimer in that standard regarding POTS compatibility. Note that the maximum number of in-line filters to be used on a Telstra provided PSTN service is 3.

Note, all relevant tests in AS/ACIF S041:2009 shall be performed at both line polarities and at both maximum and minimum line current, i.e. all relevant tests in AS/ACIF S041:2009 shall be repeated at four line conditions.

4.3.1. Clarification to the AS/ACIF Specification for the Customer End Centralised and Distributed Splitters (EXPLANATORY – not for compliance)

4.3.1.1. General Functional Description of Splitters (Section 5.3 of AS/ACIF S041.3: 2009)

4.3.1.1.1 DC Current Range

For Clause 5.3.2, feed currents up to 125mA DC may be encountered in Australia. During the transition from the Ringing to the Off-hook state, large transient currents in excess of 200mA may occur. However the requirements for testing remain as in Clause 5.3.2.

4.3.1.1.2 Reference Impedance

Note that the European harmonized impedance Z_r referred to in Clause 5.3.3 is a close match to the Australian TN12 complex impedance. Hence either impedance can be used as the reference impedance for testing. For example if the splitter passes with Z_r , then there is no need to test with TN12 (and vice versa). If a result fails marginally with Z_r , then TN12 can be used as it may pass with this slightly different impedance TN12 (and vice versa).

4.3.1.1.3 Return Loss

The return loss limit in Table 1 referenced in Clause 5.3.7 can apply to either the Z_r or TN12 impedance as described in Section 5.3.3 and Fig .1 of S041.3:2009. Other return loss requirements are based on Z_{sl} which represents a short line terminated in 600Ω .

4.3.1.1.4 POTS Compatibility Tests

Telstra's concerns regarding POTS compatibility are summarised in the following statement from AS/ACIF S041.3:2009. Filters that are compliant with AS/ACIF S041.3:2009, but which cause transient problems when deployed, will be removed from Telstra's list of approved filters.

Informative Statement on the POTS impact on ADSL2+/ADSL2/ADSL services

Because of difficulties in specification, tests relating to the impact of POTS signalling events through the filter onto the ADSL2+/ADSL2/ADSL service have not been included in this Standard. Designers of filters are advised to take into account the POTS interference mechanisms known to cause degradation of ADSL2+/ADSL2/ADSL services, as described in Clause 5.3.19.

Therefore it must be recognised that Carriers and Carriage Service Providers may need to protect their ADSL2+/ADSL2/ADSL services by not listing as approved, and actively removing from service any filter type (that may have been tested and labelled as complying to this Standard) that causes degradation due to mechanisms like those above that have not been included in this Standard.

For those parties interested in a practical test for POTS compatibility and transient issues, Telstra suggests an additional POTS compatibility test to ensure that normal telephony events do not result in loss of synchronisation or error bursts on ADSL2+ services. Two mechanisms for such loss of synchronisation or errors have been observed. The first is interference through the filter from the impulse noise caused by the operation of the telephone switch hook at seize or ring trip. The second is the compression of the ADSL2+ constellation as a result of a change in the impedance of one of the filters as part of its response to telephony events.

The most effective test to cover both mechanisms is to use a real ADSL2+ service employing a standard modem on a line connected to a DSLAM. The intended filter and modem should be used on a Telstra DSLAM. The preferred DSLAM is an Alcatel ISAM. The filter under test should be used in a standard customer premises wiring format, with a POTS feed from an exchange and a Telstra standard telephone (T1000, T400 or T300). The ADSL2+ service should be deployed at two line attenuations. The first is a line attenuation close to 56 dB at 300 kHz (or alternatively a reported MIB attenuation down of 56 dB) with an ADSL2+ profile rate of at least 3 Mbit/s, to test for the impact of transients on the ADSL2+. The second is a line attenuation of less than 10 dB at 300 kHz (or alternatively a reported MIB attenuation down of less than 15 dB). The test should use an open rate (up to 20 Mbit/s or more) profile with 6 dB target margin, to ensure that at least some of the ADSL2+ tones have the full 15 bits allocated, in order to test for the effect of impedance changes on the constellation. In each case 5 telephone calls of 30 seconds duration, and with 30 seconds between calls, should be made, and a similar set of 5 calls received with seize occurring during the ring part of the cycle. Note that a second set of tests with a decadic dial telephone might also be considered. No errors or loss of synch should occur over the whole time of the testing (Note that loss of synch often occurs up to 20 seconds after the causative event). Errors and loss of synch may be monitored either by using an Ethernet frame generator and error detector, or by monitoring the MIB of the DSLAM and modem.

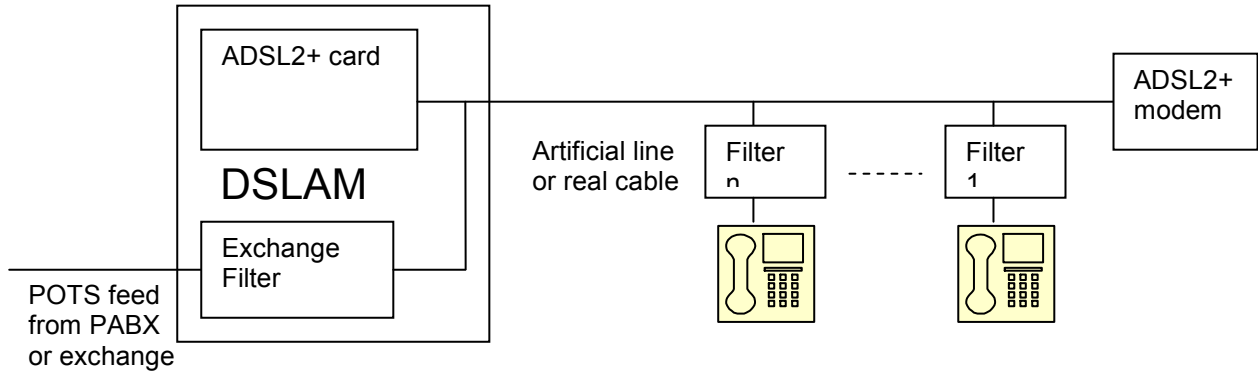

Figure 4 – Test layout for POTS compatibility testing (note: for central filter use one filter and 3 telephones)

Alternatively, a live ADSL2+ service may be used for this test, if the required line attenuations can be made from a short access line plus an artificial cable.

4.3.2. Other Requirements Applicable to Customer End Splitters (EXPLANATORY – not for compliance)

In order to avoid unacceptable attenuation of Telstra’s PSTS, the total length of the tie cable from the Network Boundary Point (NBP) to the splitter shall be as specified in "Telstra Network Termination Device, Information for Cabling Providers" Guideline 012688.

The ADSL Service Provider may apply test signals within the ADSL bands at any time provided those test signals are compliant with the ACIF Network Deployment Rules Code C559, either complying with an existing Deployment Class or demonstrated to be compliant under the provisions for Non-deployment Class systems.

Testing of the line at DC or voice frequency may only be performed when the telephone service is inactive; in this case the method of determination of inactivity and the duration of the test is to be determined in consultation with Telstra.

ADSL equipment must comply with the relevant ADSL transmit PSD masks and deployment rules of ITU-T G.992.1, ITU-T G.992.5, ACIF S043-2 and ACIF C559.

5. DEFINITIONS

The following words, acronyms and abbreviations are referred to in this document.

Term	Definition
ACMA	Australian Communications and Media Authority
ACCC	Australian Competition and Consumer Commission
Acquirer	The service provider seeking to utilise Telstra Wholesale Spectrum Sharing Service on behalf of their retail customer.
AP	Access Provider
ADSL	Asymmetric Digital Subscriber Line

BEP	Building Entry Point
CAM	Customer Access Module
CCF	Cross Connect Facility
CPE	Customer Premises Equipment
ECP	Equipment Connection Point
IDF	Intermediate Distribution Frame
MDF	Main Distribution Frame
NBP	Network Boundary Point
NTD	Network Termination Device
PSTN	Public Switched Telephone Network
PSD	Power Spectral Density
SDP	Service Delivery Point
ULLS	Unconditioned Local Loop Service

6. REFERENCES

Document Number	Title
Technical Reference RCIT.0006	Customer End Splitter Information for ADSL/POTS Spectrum Sharing
Guideline 012688	"Telstra Network Termination Device, Information for Cabling Providers"
ETSI TR 101.728 V1.2.1 (2002-05)	Access and Terminals (AT); Study for the Specification of the Low-Pass Section of POTS/ADSL Splitters
ETSI TS 101 952-1-1 V1.2.1 (2004-12)	Access network xDSL transmission filters; Part 1: ADSL splitters for European deployment; Sub-part 1: Generic specification of the low pass part of DSL over POTS splitters including dedicated annexes for specific xDSL variants
AS/ACIF S041:2009	Requirements for DSL Customer Equipment for connection to the Public Switched Telephone Network (in 3 parts)
ITU-T G.992.x	Asymmetric digital subscriber line (ADSL) transceivers standards
AS/ACIF S002: December 2001	Analogue interworking and non-interference requirements for Customer Equipment for connection to the Public Switched Telephone Network
AS/ACIF S043 - PART 1	Requirements for Customer Equipment for connection to a metallic local loop interface of a Telecommunications Network - Part 1: General
AS/ACIF S043 - PART 2	Requirements for Customer Equipment for connection to a metallic local loop interface of a Telecommunications Network - Part 2: Digital Subscriber Line (DSL)
AS/ACIF S043 - PART 3	Requirements for Customer Equipment for connection to a metallic local loop interface of a Telecommunications Network - Part 3: DC, low frequency AC and voiceband

CA/ACIF C559	INDUSTRY CODE UNCONDITIONED LOCAL LOOP SERVICE Network Deployment Rules
CA/ACIF C569	INDUSTRY CODE UNCONDITIONED LOCAL LOOP SERVICE Ordering, Provisioning and Customer Transfer
CA/ACIF G572	INDUSTRY CODE UNCONDITIONED LOCAL LOOP SERVICE Fault Management
AS/NZS 60950:2000	Safety of information technology equipment (IEC 60950:1999, MOD)
AS/NZS 3548:1995	Limits and methods of measurement of radio disturbance characteristics of information technology equipment (IEC/CISPR 22:1993)

7. DOCUMENT CONTROL SHEET

Contact for Enquiries and Proposed Changes

If you have any questions regarding this document contact:

Name: Phil Potter
 Designation: Technology Specialist
 Phone: (03) 92987155
 Email: Phil.Potter@team.telstra.com

If you have a suggestion for improving this document, complete and forward a copy of [Suggestions for Improvements to Documentation](#) (form 000 001-F01).

Record of Issues

Issue No	Issue Date	Nature of Amendment
Draft	26/4/02	Document updated to include Merv Sewell's comments.
Draft	21/05/02	Minor corrections after internal review.
Draft	22/7/2002	Separation of exchange and customer end parts
Draft	30/8/2002	Major changes due to new ETSI TS
Draft	12/9/2002	Requirement for partial HPF and DC block at exchange end.
Draft	18/9/2002	Minor corrections after internal review.
Draft	20/02/03	Corrections after being released to industry. This RCIT will change again with new ETSI Spec for distributed splitters which should be published in the next few months.
Issue 1.0	7/4/03	Requested to change to Issue 1
Issue 2.0	10/9/04	Major changes due to new ETSI TS 101 952-1-5 V1.1.1 Sub-part 5: "Specification for ADSL/POTS distributed splitters"
Issue 3.0	11/03/10	Major changes due to new Australian Standard CA/ACIF S041:2009 and updated ETSI TS 101 952-1-1 V1.2.1

This publication has been prepared and written by Telstra Corporation Limited (ABN 33 051 775 556), and is copyright. Other than for the purposes of and subject to the conditions prescribed under the Copyright Act, no part of it may in any form or by any means (electronic, mechanical, microcopying, photocopying, recording or otherwise) be reproduced, stored in a retrieval system or transmitted without prior written permission from the document controller. Product or company names are trademarks or registered trademarks of their respective holders.

Note for non-Telstra readers: The contents of this publication are subject to change without notice. All efforts have been made to ensure the accuracy of this publication. Notwithstanding, Telstra Corporation Limited does not assume responsibility for any errors nor for any consequences arising from any errors in this publication.